

WARNING

Failure to read and follow these instructions can result in death, bodily injury and/or property damage.

POISONOUS FUMES: Using a generator indoors CAN KILL YOU IN MINUTES. Engine exhaust fumes contain carbon monoxide, a poisonous gas which you cannot see or smell.

EXPLOSION HAZARD: Fuel and its vapors are extremely flammable and explosive. Allow Engine to cool at least 2 minutes before refueling.

ELECTRICAL SHOCK: Generators produce hazardous electrical voltage that can cause electrocution. Do not operate in wet conditions. When using generator for back up power, notify utility company. Use approved transfer equipment to isolate generator from electric utility.

HOT SURFACES: Engine muffler and other engine parts can become very hot. Coming in contact with hot engine components can cause serious burns.

- SUPPLIED:**
- Powerbuilt Generator unit
 Owner's Manual
- Axle Kit:**
1. Axle
 2. Mounting Hardware (2)
- Wheel Kit:**
3. 254mm Wheel (2)
 4. Mounting Hardware (2)
- Leg Kit:**
5. Leg Support
 6. Mounting Hardware (4)

- Handle Kit:**
7. Handle
 8. Mounting Hardware (2)
 9. Handle Locking Pin
- Tool Kit:**
10. Storage Pouch
 11. Large Open End Wrench
 12. Small Open End Wrench
 13. Screw Driver Handle
 14. Double Ended Screw Driver
 15. Spark Plug Wrench

16. Wrench Lever
 17. Engine Oil (10W 30)
 18. Funnel
- NEEDED:**
- Box Cutter
 Pair of Pliers
 87 Octane (or higher) Unleaded Petrol
 Protection gloves (optional)
 Safety Goggles (optional)

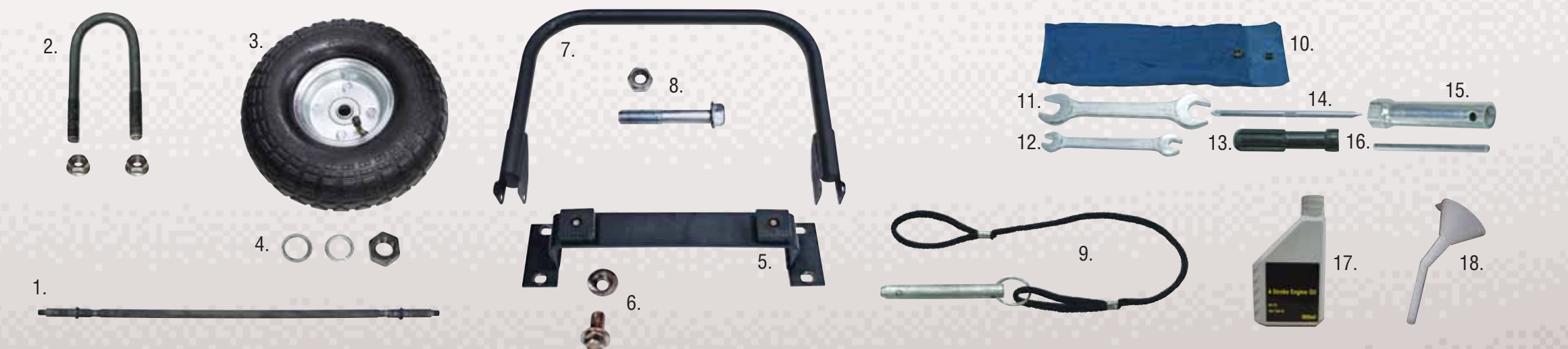

Perform ALL steps in exact order below:

1. UNPACK

- For your protection, wear protective gloves and safety goggles (not provided).
- Using a box cutter, cut open the generator carton on top and sides as shown.
- Remove all items (except the generator) and inspect for completeness (see the SUPPLIED part list above).



2. ASSEMBLE

Carefully lift the generator from the engine side and place upright.

Using the provided tools:

- Assemble the Axle(1.) to the frame by using 2 U-bolts(2.) from outside and 4 hex Nuts from inside. Tighten all hardware.



- Assemble the 2 Wheels (3.) to the Axle(1.) using flat washers(4.), lock washers (4.) and hex nuts (4.) from the outside. Tighten all hardware.



- Assemble the Leg Support (5.) to the bottom frame using hex bolts (6.) from the inside and hex nuts (6.) from the outside. Tighten all hardware.



- Assemble the Handle (7.) to the side frame using hex bolts (8.) from inside and locking hex nut (8.) from outside. Tighten all hardware.

- Loop the lanyard (9.) of the handle pin lock around the frame above the left side of the handle. Raise the handle and secure with the pin lock.

- Assembly complete – Set the generator on its wheels and supporting leg. Discard packaging and store tools for future use.

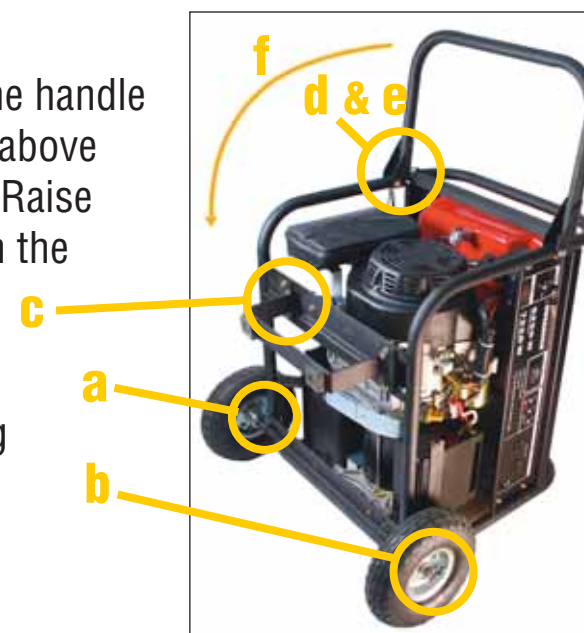

3. ADD OIL AND PETROL

Move the generator OUTSIDE and place on a flat and level surface.

• Engine Oil:

- Remove the engine oil dip stick and by using the Funnel (18.), pour the engine oil (17.) into engine until oil level reaches the threads inside the oil reservoir.

• Petrol

- Remove the fuel tank cap and add petrol to the tank. DO NOT OVERFILL. Leave room for the petrol to expand.

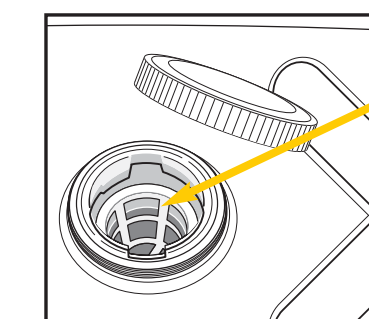

Fill Line

Hand tighten oil dip stick and gas cap and wipe off any spilled oil or fuel.
 Fuel type: 87 Octane (or higher) unleaded petrol.



4. PREPARATION

- Place in a fully VENTILATED area and on a FLAT and level surface.
- Keep a minimum of 1.5M CLEARANCE on all sides of the engine including top.
- Face the generator exhaust outlet AWAY from dwellings.

DANGER

Using a generator indoors WILL KILL YOU IN MINUTES. Exhaust fumes contain carbon monoxide, a poisonous gas you cannot see or smell.

NEVER use in the home or in partly enclosed areas such as garages.

ONLY use outdoors and far from open windows, doors, and vents.

Avoid other generator hazards. READ MANUAL BEFORE USE.

WARNING

Failure to read and follow these instructions can result in death, bodily injury and/or property damage.

WEAR APPROVED EYE PROTECTION: This tool has rotating and moving parts that could become airborne if damaged. Always wear approved eye protection when operating equipment with moving parts. Safety glasses must conform to the requirements and provide protection against flying particles from both front and side.

ROTATING PARTS: Starter and other rotating parts on this tool can entangle loose clothing, long hair and accessories resulting in moderate to severe injury.

KICKBACK: Starter cord can kickback (recoil) very rapidly. Kickback will recoil starter cord quicker than you can let go. This action can result in broken bones, bruises, sprains or fractures.

Unit is heavy: Take care when lifting or moving unit.

5. CONNECTING THE BATTERY (MAINTENANCE FREE BATTERY PROVIDED)

Note: Before using the key start function of the generator you must connect the battery to the generator. The battery negative cable connected to the battery terminal bolt on the negative terminal (black logo side), then use a wrench to tighten. (see Fig. A)

6. STARTING THE ENGINE WITH KEY START

- Before starting, ensure that no electrical apparatus has been connected to the generator.
- Turn the Fuel Valve lever counterclockwise to "ON" position to allow the fuel to flow to the engine.
 - Slide the Choke Lever to "START"(left) position.
 - Turn the key start ignition clockwise to the "START" position. (see Fig.B)

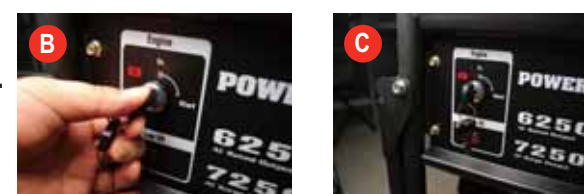

Note: When the engine is being started for the very first time, it may require a number of attempts to start until the petrol has travelled from the tank to the engine. d. Once you hear the engine operating, release the key to allow the position to move from "START" to "ON". (see Fig.C)

- Slide the Choke Lever to "RUN"(right) position.

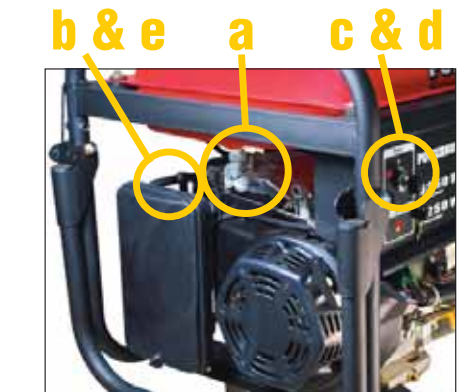

7. STARTING THE ENGINE MANUALLY

Note: Follow steps (a.) to (b.) of the 'Starting the engine with key start' section.

- Turn the key start ignition clockwise to the 'ON' (see Fig. D).
- To start the engine, pull Starter cord slowly until resistance is felt, then pull rapidly to avoid kick back. Repeat until engine starts to run.
- Once you hear the engine operating, Slide the Choke Lever to "RUN"(right) position.

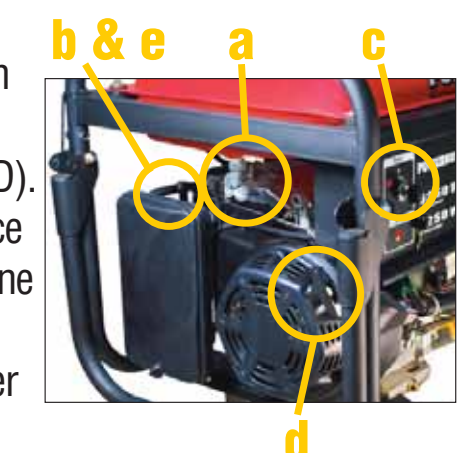

- NEVER start or stop generator engine with electrical devices plugged in and/or turned on. Damage to both electrical devices and generator can occur.
- Ensure generator is sitting on a level surface.
- When starting generator engine, pull cord slowly until resistance is felt, then pull rapidly to avoid kickback.



8. CONNECT

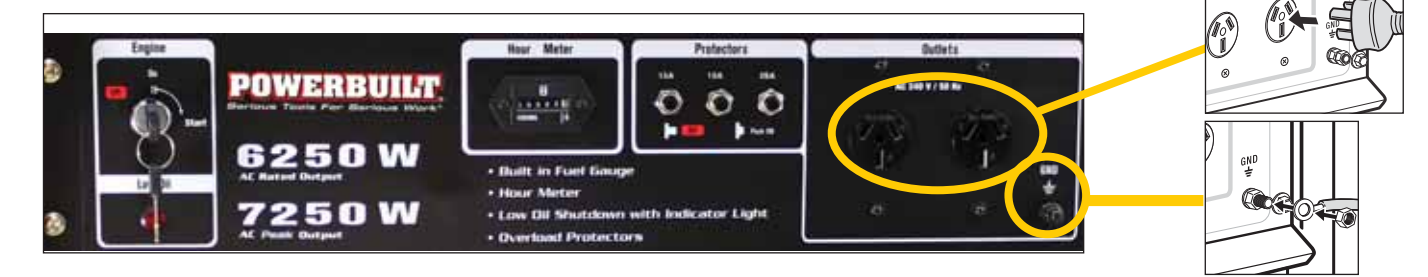

- When required connect the generator's System Ground terminal located in the lower right corner of the front panel to an approved Earth Ground. Consult owner's manual for more information.
- Make sure ALL loads (electrical appliances) are turned OFF.
- Connect the loads to the outlets. DO NOT exceed amperage (A) capacity of the outlets. Consult owner's manual for more information.
- Turn on the loads one at a time. Turn off the load if it causes engine to shake excessively.

9. STOPPING THE GENERATOR

- Turn OFF and disconnect all electrical loads from generator panel outlets. NEVER start or stop engine with electrical devices plugged in and turned ON.
- Let engine run at a no-load speed for several minutes to stabilize internal temperatures of the engine and generator.
- Turn the key start ignition to the 'OFF' position (see Fig.E).
- Turn fuel valve to "OFF" (clockwise) position.



10. STORE

Refer to Owner's Manual for storage instructions.

